

JETON®

www.jeton.com.tw

High Pressure Adjustable Nozzle
Spraying Device



JETON R/D & MFG. INC.
宏明工業股份有限公司 / 宏啓工業股份有限公司
No. 17, Lane 100, Tsao-Tyi Road, Ta-Li Dist., Taichung, Taiwan R.O.C.
台灣台中市大里區草堤路100巷17號
TEL: 886 - 4 - 24953456
FAX: 886 - 4 - 24953399
E-MAIL: jetoninc@seed.net.tw

上海奇晉貿易有限公司
上海市虹口區大連路1079號2307室
TEL: 021 - 65622765 . 021 - 65623571
FAX: 021 - 65159705
E-MAIL: jetoninc@163.com

JETON®
www.jeton.com.tw

It is our great pleasure introducing JETON R/D & MFG. INC.
This is a company has more than 20 year's extensive experiences in the field of Injection Industrial and we major manufacture and market JETON ADJUSTABLE COOLANT HOSE, HIGH PRESSURE ADJUSTABLE NOZZLE, VACUUM FLEX TUBE, DOLL ARMATURE.
JETON is one of the leading manufacturers in INJECTION INDUSTRIAL from 1983 especially in ADJUSTABLE COOLANT HOSE for machine tools.
In 1989, we use the reason of COOLANT HOSE to develop the product for Doll in ARMATURE that could be put into the stuff toys or ceramic doll, soft body and so on. It's made the toy to be looked life-like very much.
In 1994, we extend the range of toy's accessory with great varieties. In 1996, we use the modern techniques to combine and develop with flexible structuring parts for applications.
Nowadays we rename JETON R/D & MFG. INC. (Original: HONG CHYE INDUSTRIAL CO., LTD.) and hope you to support us in the future.

CONTENTS

High Pressure Adjustable Nozzle

High Pressure Adjustable Nozzle..... 03-04
 Inclined-injection Type..... 05-06
 Direct-injection Type..... 07-08
 Mounted Type..... 09-10
 Easy Jet-on Type..... 11-12
 Examples Of Application..... 13-14

Spraying Device

Spraying Device.....15-16



Omnipotent



HIGH PRESSURE ADJUSTABLE NOZZLE
High Pressure Adjustable Nozzle

High Pressure Adjustable Nozzle

High pressure adjustable nozzle can elevate the working efficiency, enhance accuracy of product, protect the service life of cutting tools, curtail working hours, and lower cost that makes it an efficient instrument to enhance the competitiveness.

- ▶ It's specially-designed mechanical structure can bring out an adjustable angle featuring 360° gyration after the oblique 34° angle, thus helping adjust a wide injection range.
- ▶ A choice of quality material along with accurate assembly to develop the greatest function of high pressure adjustable nozzle.
- ▶ The compression resistance to be at 30 kgf/cm².
- ▶ A wide range of adjustable angle, an easy adjustment.
- ▶ Steady and accurate positioning with no spring-back.
- ▶ Applied to the spraying, cooling system and ejector system of each type of machine.



MODEL

INCLINED-INJECTION TYPE

The injection direction forms one angle with the fixed direction and is applied widely to deviated spraying cooling system, such as turret of the CNC lathe.

DIRECT-INJECTION TYPE

The injection direction is paralleled to the fixed direction and is widely applied to variety of CNC machining center, grinding machine, and each machining tool.

MOUNTED TYPE

The injection direction is paralleled to the fixed direction, but the fixed direction uses the close fit for a mount and is applied to each CNC system.

EASY JET-ON TYPE

The injection direction forms one angle with the fixed direction, but the fixed direction uses the close fit for a mount and is applied to each CNC system.



PRESSURE CONVERSION TABLE:

Kgf / cm ²	Bar	KPa	PSI	Torr mmHg	atm
1	= 0.981	98.067	14.223	735.559	0.968
30	= 29.420	2941.995	426.693	22066.77	29.034

HIGH PRESSURE ADJUSTABLE NOZZLE

Omnipotent



Omnipotent

PATENT CERTIFICATION

Inclined-Injection High Pressure Adjustable Nozzle

The injection direction forms one angle with the fixed direction and is applied widely to deviated spraying cooling system, such as turret of the CNC lathe.

- ▶ Easy adjustable angle.
- ▶ Accurate and steady positioning.
- ▶ Element cleaning after the machining process.
- ▶ Get the "water" power ready to inject cutting tool, secure the cooling of the cutters in the machining course to extend the service life of cutters.
- ▶ Strong injection cooling system makes the filing strap won't wind around the lathe tool and secure the elements more accuracy and the surface more smooth during the machining process.
- ▶ Applied to spraying and cooling system and enector of each type of machine.

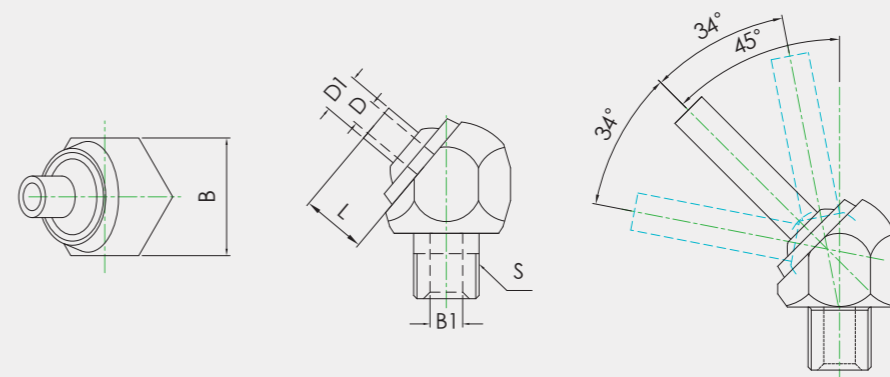

Specifications for Inclined-Injection High Pressure Adjustable Nozzle

Item No.	Specifications	Major Size					Unit (mm)	
		D	THREAD(S)	L	D1	B1	HEXAGRAM(B)	
JTAP-1/8-10	1/8"PT-Ø4*10L	4	PT 1/8"	10	6	6	17	
JTAP-1/8-30	1/8"PT-Ø4*30L	4	PT 1/8"	30	6	6	17	
JTAP-1/8-50	1/8"PT-Ø4*50L	4	PT 1/8"	50	6	6	17	
JTAP-1/4-10	1/4"PT-Ø4*10L	4	PT 1/4"	10	6	6	17	
JTAP-1/4-30	1/4"PT-Ø4*30L	4	PT 1/4"	30	6	6	17	
JTAP-1/4-50	1/4"PT-Ø4*50L	4	PT 1/4"	50	6	6	17	
JTAP-3/8-20	3/8"PT-Ø6*20L	6	PT 3/8"	20	8	10	24	
JTAP-3/8-40	3/8"PT-Ø6*40L	6	PT 3/8"	40	8	10	24	
JTAP-3/8-60	3/8"PT-Ø6*60L	6	PT 3/8"	60	8	10	24	
JTAP-1/2-30	1/2"PT-Ø8*30L	8	PT 1/2"	30	10	12	32	
JTAP-1/2-50	1/2"PT-Ø8*50L	8	PT 1/2"	50	10	12	32	
JTAP-1/2-70	1/2"PT-Ø8*70L	8	PT 1/2"	70	10	12	32	

Item No.	Specifications	Major Size					Unit (mm)	
		D	THREAD(S)	L	D1	B1	HEXAGRAM(B)	
JTAN-1/8-10	1/8"NPT-Ø4*10L	4	NPT 1/8"	10	6	6	17	
JTAN-1/8-30	1/8"NPT-Ø4*30L	4	NPT 1/8"	30	6	6	17	
JTAN-1/8-50	1/8"NPT-Ø4*50L	4	NPT 1/8"	50	6	6	17	
JTAN-1/4-10	1/4"NPT-Ø4*10L	4	NPT 1/4"	10	6	6	17	
JTAN-1/4-30	1/4"NPT-Ø4*30L	4	NPT 1/4"	30	6	6	17	
JTAN-1/4-50	1/4"NPT-Ø4*50L	4	NPT 1/4"	50	6	6	17	
JTAN-3/8-20	3/8"NPT-Ø6*20L	6	NPT 3/8"	20	8	10	24	
JTAN-3/8-40	3/8"NPT-Ø6*40L	6	NPT 3/8"	40	8	10	24	
JTAN-3/8-60	3/8"NPT-Ø6*60L	6	NPT 3/8"	60	8	10	24	
JTAN-1/2-30	1/2"NPT-Ø8*30L	8	NPT 1/2"	30	10	12	32	
JTAN-1/2-50	1/2"NPT-Ø8*50L	8	NPT 1/2"	50	10	12	32	
JTAN-1/2-70	1/2"NPT-Ø8*70L	8	NPT 1/2"	70	10	12	32	

Item No.	Specifications	Major Size					Unit (mm)	
		D	THREAD(S)	L	D1	B1	HEXAGRAM(B)	
JTAM-10-10	M10*1.25P-Ø4*10L	4	M10*1.25P	10	6	6	17	
JTAM-10-30	M10*1.25P-Ø4*30L	4	M10*1.25P	30	6	6	17	
JTAM-10-50	M10*1.25P-Ø4*50L	4	M10*1.25P	50	6	6	17	

Item No.	Specifications	Major Size					Unit (mm)	
		D	THREAD(S)	L	D1	B1	HEXAGRAM(B)	
JTAP2-1/8-10	1/8"PT-Ø3*10L	3	PT 1/8"	10	5	5	14	
JTAP2-1/8-20	1/8"PT-Ø3*20L	3	PT 1/8"	20	5	5	14	
JTAP2-3/8-10	3/8"PT-Ø6*10L	4	PT 3/8"	10	6	6	17	
JTAP2-3/8-30	3/8"PT-Ø6*30L	4	PT 3/8"	30	6	6	17	
JTAP2-3/8-50	3/8"PT-Ø6*50L	4	PT 3/8"	50	6	6	17	

Item No.	Specifications	Major Size					Unit (mm)	
		D	THREAD(S)	L	D1	B1	HEXAGRAM(B)	
JTAN2-1/8-10	1/8"NPT-Ø3*10L	3	NPT 1/8"	10	5	5	14	
JTAN2-1/8-20	1/8"NPT-Ø3*20L	3	NPT 1/8"	20	5	5	14	
JTAN2-3/8-10	3/8"NPT-Ø6*10L	4	NPT 3/8"	10	6	6	17	
JTAN2-3/8-30	3/8"NPT-Ø6*30L	4	NPT 3/8"	30	6	6	17	
JTAN2-3/8-50	3/8"NPT-Ø6*50L	4	NPT 3/8"	50	6	6	17	

Item No.	Specifications	Major Size					Unit (mm)	
		D	THREAD(S)	L	D1	B1	HEXAGRAM(B)	
JTAM2-8-10	M8*1.25P-Ø3*10L	3	M8*1.25P	10	5	4.5	14	
JTAM2-8-20	M8*1.25P-Ø3*20L	3	M8*1.25P	20	5	4.5	14	

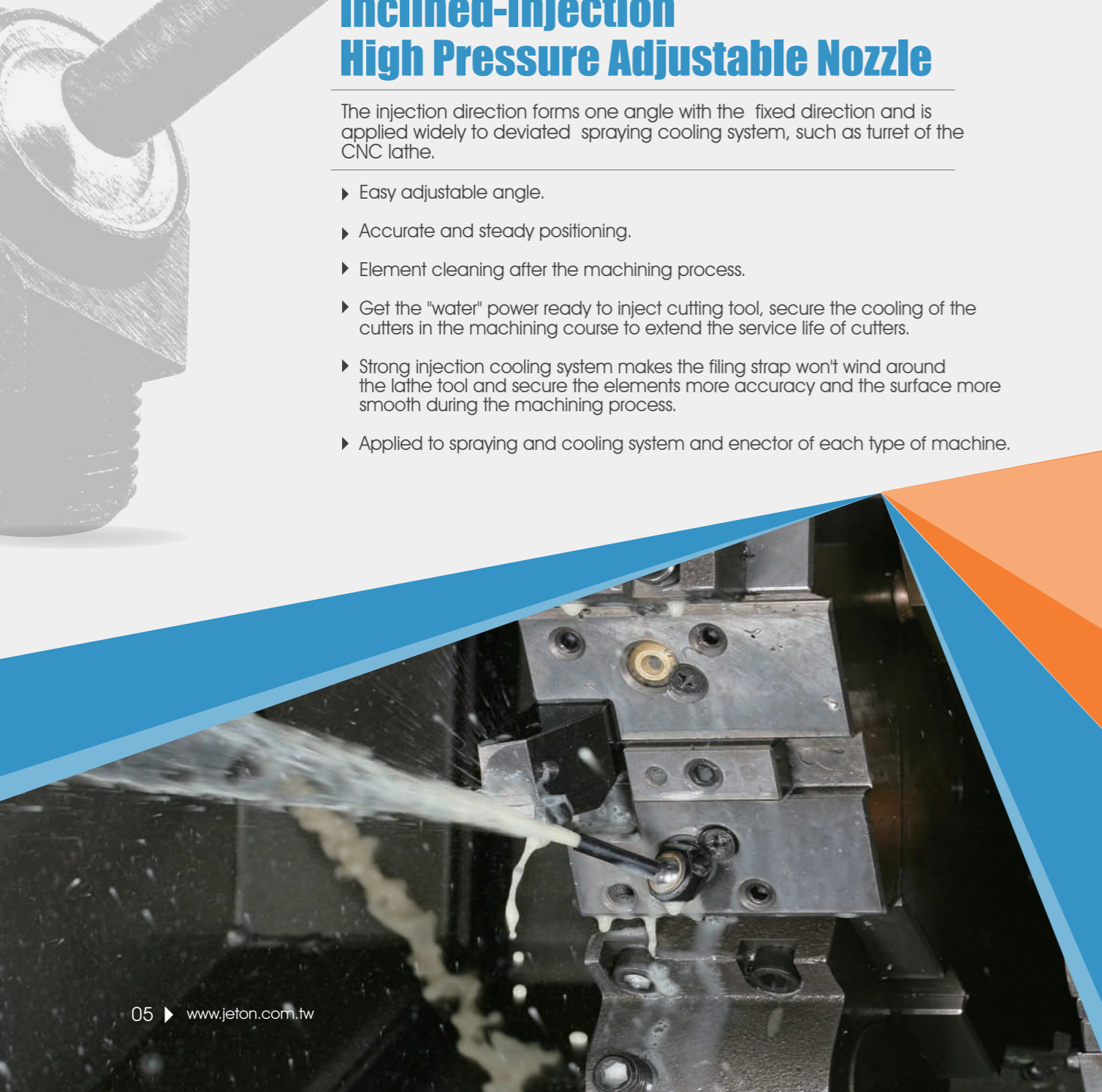

Omnipotent

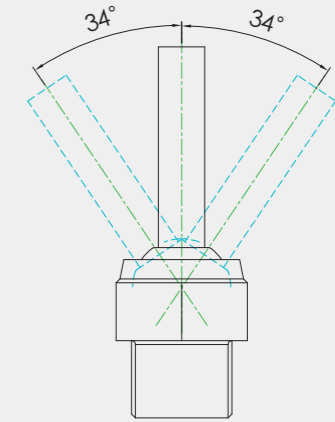
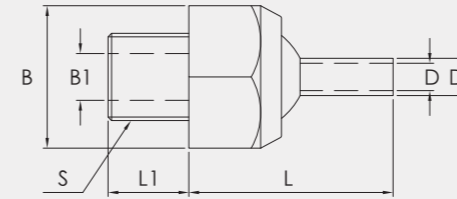

Direct-Injection High Pressure Adjustable Nozzle

The injection direction is paralleled to the fixed direction, with the screw to be used to make the fixed method. It is widely applied to the spraying and cooling system and ejector of each type of machine.

- ▶ Easy adjustable angle.
- ▶ Accurate and steady positioning, with no spring-back.
- ▶ Get the "water" power ready for an accurate injection towards milling cutter or drill, thus securing the sufficient cooling for cutter or drill during the machining process and extending its service life.
- ▶ Applied widely to the spraying and cooling system and ejector of each type of machine.

Specifications for Direct-Injection High Pressure Adjustable Nozzle

Item No.	Specifications	Major Size						Unit (mm)	
		D	THREAD(S)	L	L1	D1	B1	HEXAGRAM(B)	
JTSP-1/8-20	1/8"PT-Ø4*20L	4	PT 1/8"	20	10	6	6	17	
JTSP-1/8-40	1/8"PT-Ø4*40L	4	PT 1/8"	40	10	6	6	17	
JTSP-1/8-60	1/8"PT-Ø4*60L	4	PT 1/8"	60	10	6	6	17	
JTSP-1/4-20	1/4"PT-Ø4*20L	4	PT 1/4"	20	10	6	6	17	
JTSP-1/4-40	1/4"PT-Ø4*40L	4	PT 1/4"	40	10	6	6	17	
JTSP-1/4-60	1/4"PT-Ø4*60L	4	PT 1/4"	60	10	6	6	17	
JTSP-3/8-30	3/8"PT-Ø6*30L	6	PT 3/8"	30	13	8	10	24	
JTSP-3/8-50	3/8"PT-Ø6*50L	6	PT 3/8"	50	13	8	10	24	
JTSP-3/8-70	3/8"PT-Ø6*70L	6	PT 3/8"	70	13	8	10	24	
JTSP-1/2-40	1/2"PT-Ø8*40L	8	PT 1/2"	40	18	10	12	32	
JTSP-1/2-60	1/2"PT-Ø8*60L	8	PT 1/2"	60	18	10	12	32	
JTSP-1/2-80	1/2"PT-Ø8*80L	8	PT 1/2"	80	18	10	12	32	

Item No.	Specifications	Major Size						Unit (mm)	
		D	THREAD(S)	L	L1	D1	B1	HEXAGRAM(B)	
JTSN-1/8-20	1/8"NPT-Ø4*20L	4	NPT 1/8"	20	10	6	6	17	
JTSN-1/8-40	1/8"NPT-Ø4*40L	4	NPT 1/8"	40	10	6	6	17	
JTSN-1/8-60	1/8"NPT-Ø4*60L	4	NPT 1/8"	60	10	6	6	17	
JTSN-1/4-20	1/4"NPT-Ø4*20L	4	NPT 1/4"	20	10	6	6	17	
JTSN-1/4-40	1/4"NPT-Ø4*40L	4	NPT 1/4"	40	10	6	6	17	
JTSN-1/4-60	1/4"NPT-Ø4*60L	4	NPT 1/4"	60	10	6	6	17	
JTSN-3/8-30	3/8"NPT-Ø6*30L	6	NPT 3/8"	30	13	8	10	24	
JTSN-3/8-50	3/8"NPT-Ø6*50L	6	NPT 3/8"	50	13	8	10	24	
JTSN-3/8-70	3/8"NPT-Ø6*70L	6	NPT 3/8"	70	13	8	10	24	
JTSN-1/2-40	1/2"NPT-Ø8*40L	8	NPT 1/2"	40	18	10	12	32	
JTSN-1/2-60	1/2"NPT-Ø8*60L	8	NPT 1/2"	60	18	10	12	32	
JTSN-1/2-80	1/2"NPT-Ø8*80L	8	NPT 1/2"	80	18	10	12	32	

Item No.	Specifications	Major Size						Unit (mm)	
		D	THREAD(S)	L	L1	D1	B1	HEXAGRAM(B)	
JTSM-10-15	M10*1.25P-Ø4*15L	4	M10*1.25P	15	10	6	6	17	
JTSM-10-20	M10*1.25P-Ø4*20L	4	M10*1.25P	20	10	6	6	17	
JTSM-10-40	M10*1.25P-Ø4*40L	4	M10*1.25P	40	10	6	6	17	
JTSM-10-60	M10*1.25P-Ø4*60L	4	M10*1.25P	60	10	6	6	17	
JTSM-20-30	M10*1.5P-Ø6*30L	6	M20*1.5P	30	13	8	10	24	
JTSM-20-50	M10*1.5P-Ø6*50L	6	M20*1.5P	50	13	8	10	24	
JTSM-20-70	M10*1.5P-Ø6*70L	6	M20*1.5P	70	13	8	10	24	
JTSM-24-40	M10*2.0P-Ø8*40L	8	M24*2.0P	40	18	10	12	32	
JTSM-24-60	M10*2.0P-Ø8*60L	8	M24*2.0P	60	18	10	12	32	
JTSM-24-80	M10*2.0P-Ø8*80L	8	M24*2.0P	80	18	10	12	32	

High Pressure Adjustable Nozzle Spraying Device

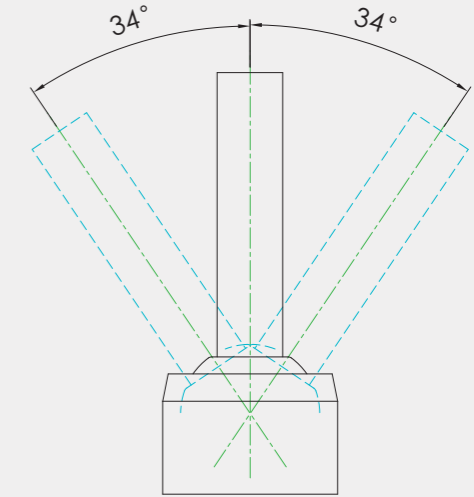
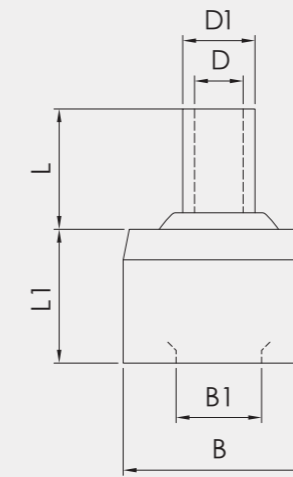

Mounted High Pressure Adjustable Nozzle

The injection direction is paralleled to the fixed direction, with the fixed method adopting the close fit for the mount. It is widely applied to the spraying and cooling system and ejector of each type of machine.

- ▶ Easy adjustable angle.
- ▶ Accurate and steady positioning, with no spring-back.
- ▶ Get the "water" power ready for an accurate injection towards milling cutter or drill, thus securing the sufficient cooling for cutter or drill during the machining process and extending its service life.
- ▶ Applied widely to the spraying and cooling system and ejector of each type of machine.

Specifications for Mounted High Pressure Adjustable Nozzle

Item No.	Specifications	Major Size					Unit (mm)	
		D	L	D1	L1	B1	Ø(B)	
JTDP-10	Ø10*Ø2	2	1	3	8	4.5	10	
JTDP-12-5	Ø12*Ø2*5L	2	5	4	8	5.5	12	

Item No.	Specifications	Major Size					Unit (mm)	
		D	L	D1	L1	B1	Ø(B)	
JTDP-14-8	Ø14*Ø3*8L	3	8	5	8	7	14	

Item No.	Specifications	Major Size					Unit (mm)	
		D	L	D1	L1	B1	Ø(B)	
JTDP-15-5	Ø15*Ø4*5L	4	5	6	8	7	15	
JTDP-15-10	Ø15*Ø4*10L	4	10	6	8	7	15	
JTDP-15-30	Ø15*Ø4*30L	4	30	6	8	7	15	
JTDP-15-50	Ø15*Ø4*50L	4	50	6	8	7	15	

Item No.	Specifications	Major Size					Unit (mm)	
		D	L	D1	L1	B1	Ø(B)	
JTDP-16-5	Ø16*Ø4*5L	4	5	6	11	7	16	
JTDP-16-10	Ø16*Ø4*10L	4	10	6	11	7	16	
JTDP-16-30	Ø16*Ø4*30L	4	30	6	11	7	16	
JTDP-16-50	Ø16*Ø4*50L	4	50	6	11	7	16	

High Pressure Adjustable Nozzle Spraying Device



Omnipotent

NEW

Easy Jet-On High Pressure Adjustable Nozzle

The injection direction forms one angle with the fixed direction, but the fixed direction uses the close fit for a mount and is applied to each CNC system.

- ▶ Easy adjustable angle.
- ▶ Accurate and steady positioning, with no spring-back.
- ▶ Get the "water" power ready for an accurate injection towards milling cutter or drill, thus securing the sufficient cooling for cutter or drill during the machining process and extending its service life.
- ▶ Applied widely to the spraying and cooling system and ejector of each type of machine.

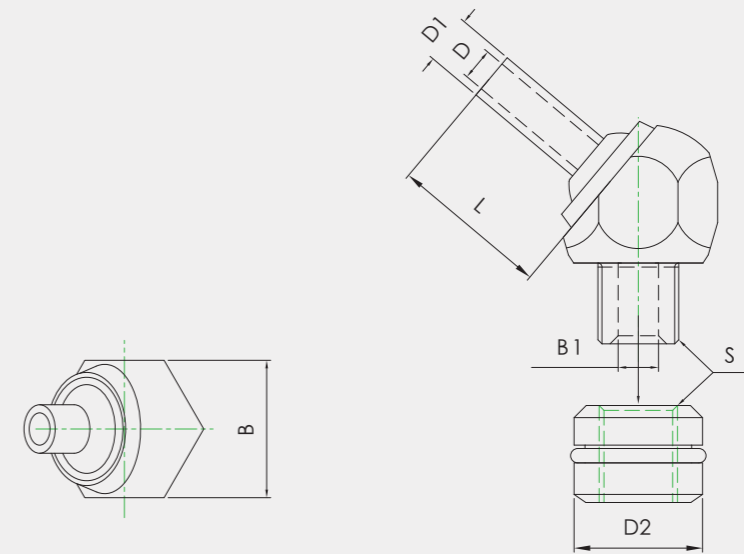

Specifications for Easy Jet-On High Pressure Adjustable Nozzle

Item No.	Specifications	Major Size						Unit (mm)	
		D2	D	THREAD(S)	L	D1	B1	HEXAGRAM(B)	
JTAT-14-1/8-10	1/8"PT-Ø4*10L	14	4	PT 1/8"	10	6	6	17	
JTAT-14-1/8-30	1/8"PT-Ø4*30L	14	4	PT 1/8"	30	6	6	17	
JTAT-14-1/8-50	1/8"PT-Ø4*50L	14	4	PT 1/8"	50	6	6	17	

Item No.	Specifications	Major Size						Unit (mm)	
		D2	D	THREAD(S)	L	D1	B1	HEXAGRAM(B)	
JTAT-15-1/8-10	1/8"PT-Ø4*10L	15	4	PT 1/8"	10	6	6	17	
JTAT-15-1/8-30	1/8"PT-Ø4*30L	15	4	PT 1/8"	30	6	6	17	
JTAT-15-1/8-50	1/8"PT-Ø4*50L	15	4	PT 1/8"	50	6	6	17	

Item No.	Specifications	Major Size						Unit (mm)	
		D2	D	THREAD(S)	L	D1	B1	HEXAGRAM(B)	
JTAT-16-1/8-10	1/8"PT-Ø4*10L	16	4	PT 1/8"	10	6	6	17	
JTAT-16-1/8-30	1/8"PT-Ø4*30L	16	4	PT 1/8"	30	6	6	17	
JTAT-16-1/8-50	1/8"PT-Ø4*50L	16	4	PT 1/8"	50	6	6	17	

Item No.	Specifications	Major Size						Unit (mm)	
		D2	D	THREAD(S)	L	D1	B1	HEXAGRAM(B)	
JTAT-18-1/8-10	1/8"PT-Ø4*10L	18	4	PT 1/8"	10	6	6	17	
JTAT-18-1/8-30	1/8"PT-Ø4*30L	18	4	PT 1/8"	30	6	6	17	
JTAT-18-1/8-50	1/8"PT-Ø4*50L	18	4	PT 1/8"	50	6	6	17	

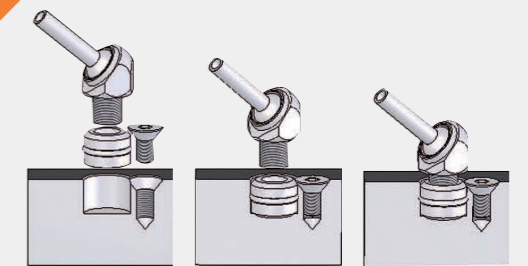

High Pressure Adjustable Nozzle Spraying Device

Examples of Application

Examples of Application

- ▶ Five multi-faceted direction of cooling injections.
- ▶ Strong injection cooling system will secure the cooling in the machining process.
- ▶ Strong injection cooling system will further clean out the dregs on diamond wheel, thus making more sharpened and extend its service life.
- ▶ Strong injection cooling system will further clean out the dregs on working table and bring out a clean workpiece.



Example of Use for Cutting Grinder

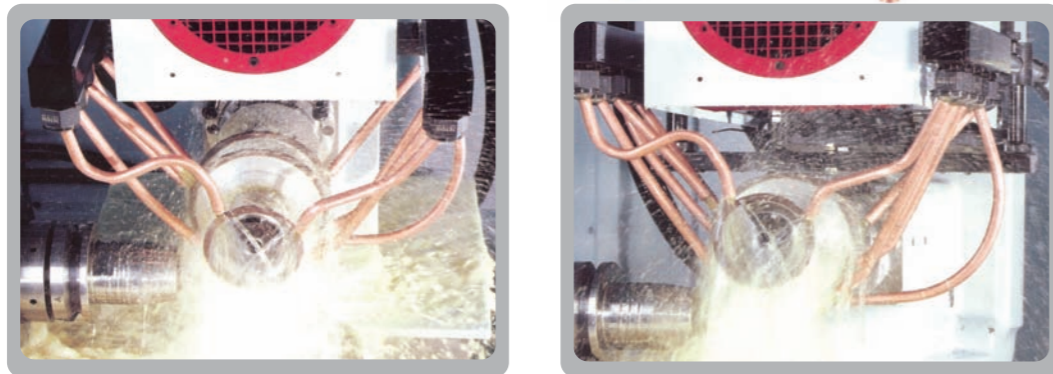

Examples of Application

- ▶ Five multi-faceted direction of cooling injections.
- ▶ Strong injection cooling system will secure the cooling in the machining process.
- ▶ Strong injection cooling system will further clean out the dregs on diamond wheel, thus making more sharpened and extend its service life.
- ▶ Strong injection cooling system will further clean out the dregs on working table and bring out a clean workpiece.



Pneumatic Machine to Cutting Grinder

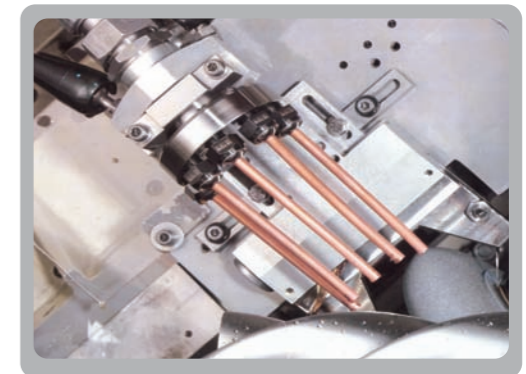

Examples of Application

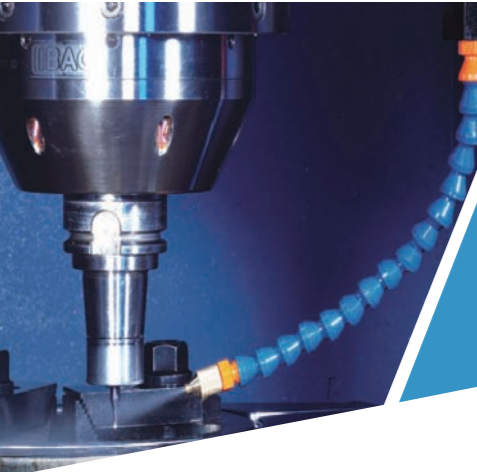

SPRAYING DEVICE

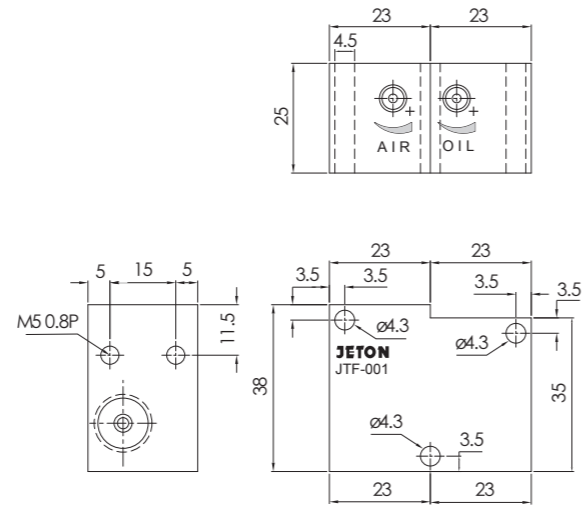

Spraying Device

- JTF-001**
SPRAYING DEVICE
- ▶ Aluminum Base 1 set
 - ▶ 1/4" Adjustable Coolant Hoses 1 piece
 - ▶ A Spray Nozzle 1 piece

- ▶ Applied to cool the micro-cutting under the high-speed.
- ▶ Two inlet ports, one for oil, and the other one for air.
- ▶ Adjust bolt to adjust the oil and air.
- ▶ The pressure exportation oil and air.

Recommend the use of pressure:
 Atmospheric pressure: 0.5~5 kg/cm²
 Hydraulic pressure: 0.5~2 kg/cm²

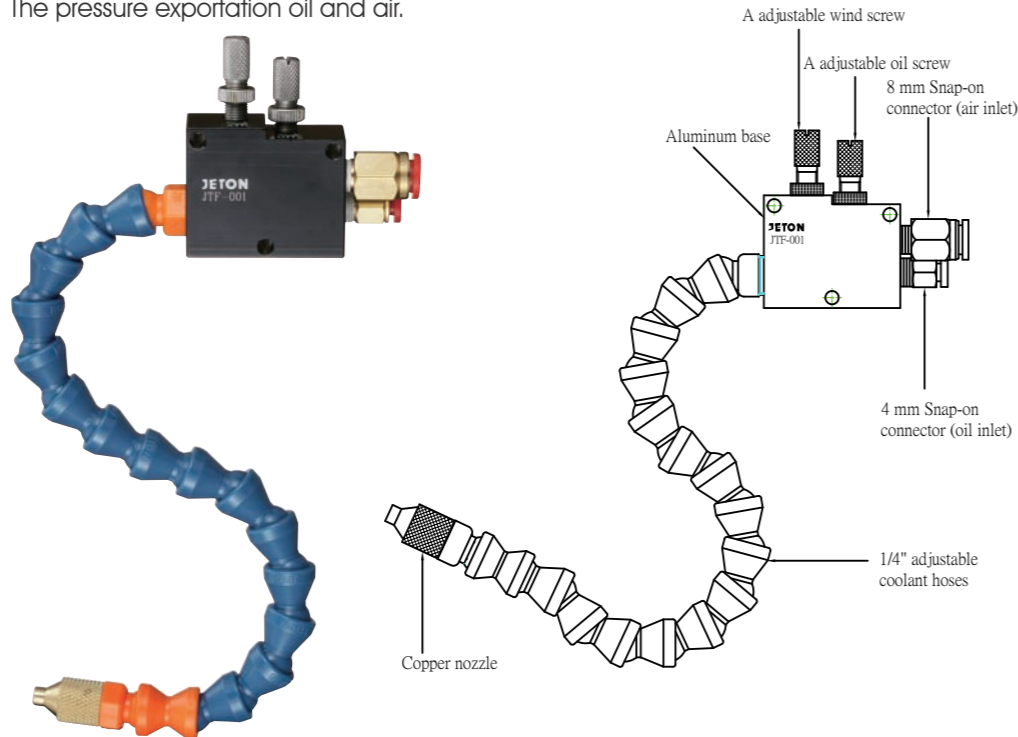

Spraying Device

- JTF-002**
SPRAYING DEVICE
- ▶ Aluminum Base 1 set
 - ▶ 1/4" Adjustable Coolant Hoses 1 piece
 - ▶ A Spray Nozzle 1 piece

- ▶ Applied to cool the micro-cutting under the high-speed.
- ▶ Two inlet ports, one for oil, and the other one for air.
- ▶ Adjust bolt to adjust the oil and air.
- ▶ The pressure exportation oil and air.

Recommend the use of pressure:
 Atmospheric pressure: 3.5~5 kg/cm²
 Hydraulic pressure: 0

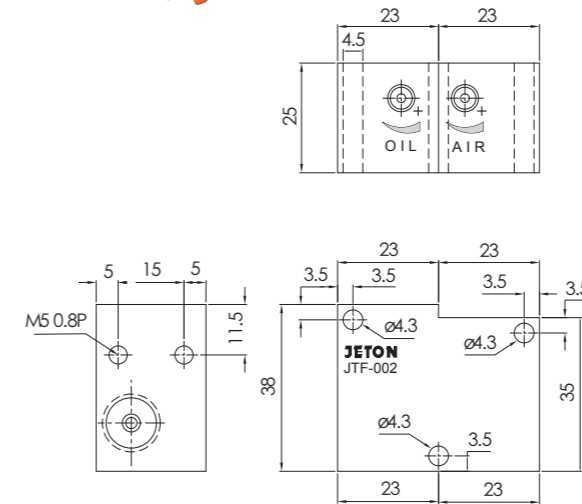
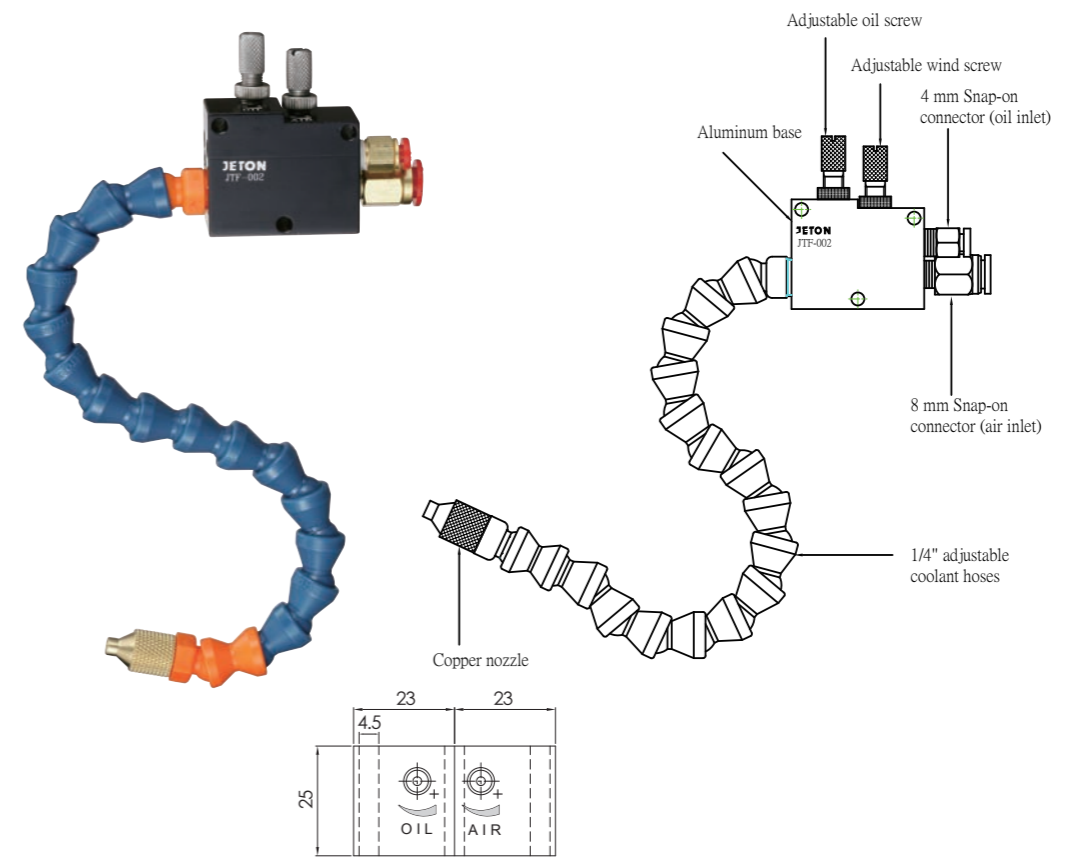

High Pressure Adjustable Nozzle Spraying Device

Omnipotent

ISO 9001:2008 CERTIFIED
www.jeton.com.tw

